

GENERAL NOTES:

ALL AREAS WHERE EXISTING VEGETATION AND GRASS COVER HAVE BEEN BARED BY CONSTRUCTION SHALL BE ADEQUATELY BLOCK SODDED OR HYDROMULCHED AND WATERED UNTIL GROWTH IS ESTABLISHED. IN DEVELOPED AREAS WHERE GRASS IS PRESENT, BLOCK SOD WILL BE REQUIRED. BARED AREAS SHALL BE SEEDED OR SODDED WITHIN 14 CALENDAR DAYS OF LAST DISTURBANCE.

APPROVED EROSION CONTROL MEASURES MUST BE INSTALLED DURING THE ENTIRE TIME THAT EARTH HAS BEEN BARED BY CONSTRUCTION AND SHALL STAY IN PLACE UNTIL ACCEPTABLE VEGETATIVE GROWTH IS ESTABLISHED AFTER CONSTRUCTION IS COMPLETE AND THEN REMOVED BY CONTRACTOR.

ALL EROSION CONTROL MEASURES SHOULD BE CLEANED OF SILT AFTER EVERY RAIN.

ALL TRAFFIC SIGNALS AND APPURTENANCES, AND ALL PAVEMENT MARKINGS AND MARKERS SHALL BE IN ACCORDANCE WITH TXDOT STANDARDS

REFER TO SPEC 31 17 23.23 (PAVEMENT MARKINGS) FOR ADDITIONAL LOCAL REQUIREMENTS.

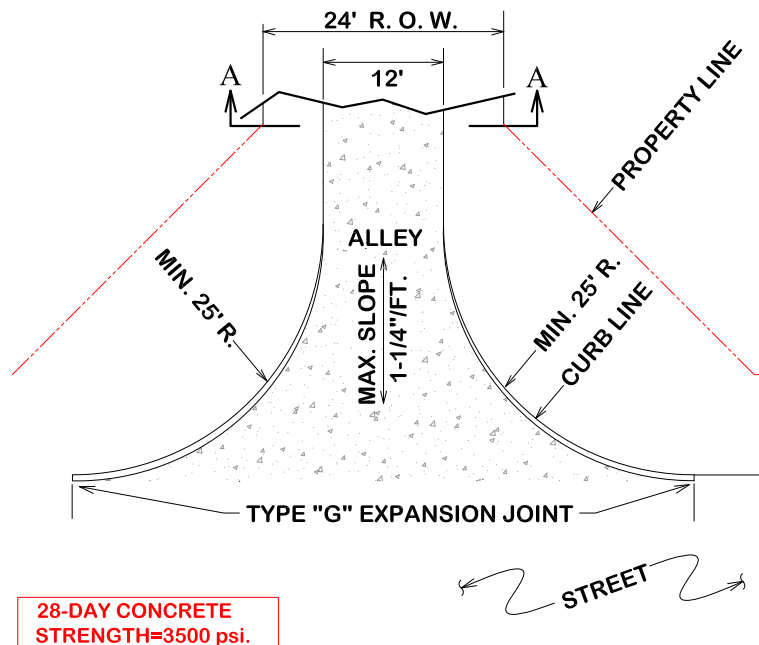
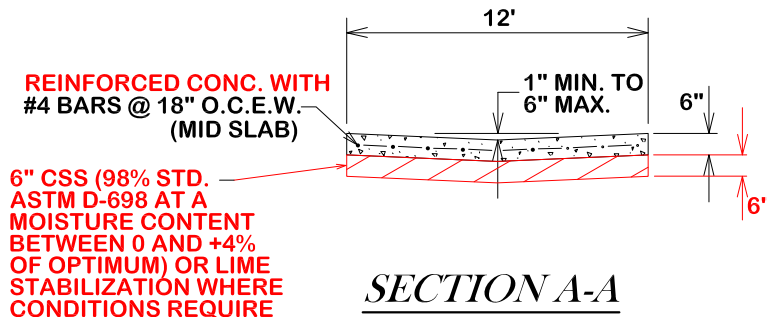

CITY OF BRYAN
The Good Life, Texas Style.

ALLEY PAVING

DATE

FEB. 2021

**B/CS UNIFIED
STANDARD DETAIL**

DETAIL NO.

ST1-06



CITY OF COLLEGE STATION