

SIDEWALK CONTRACTION JOINT

TYPE "G" SIDEWALK EXPANSION & CONSTRUCTION JOINT

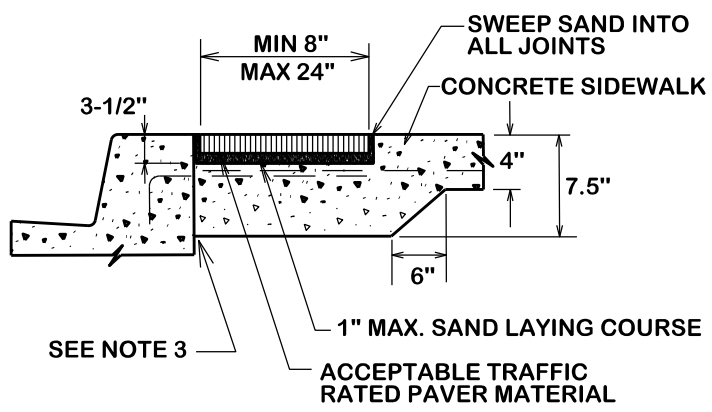

SIDEWALK PAVER SECTION

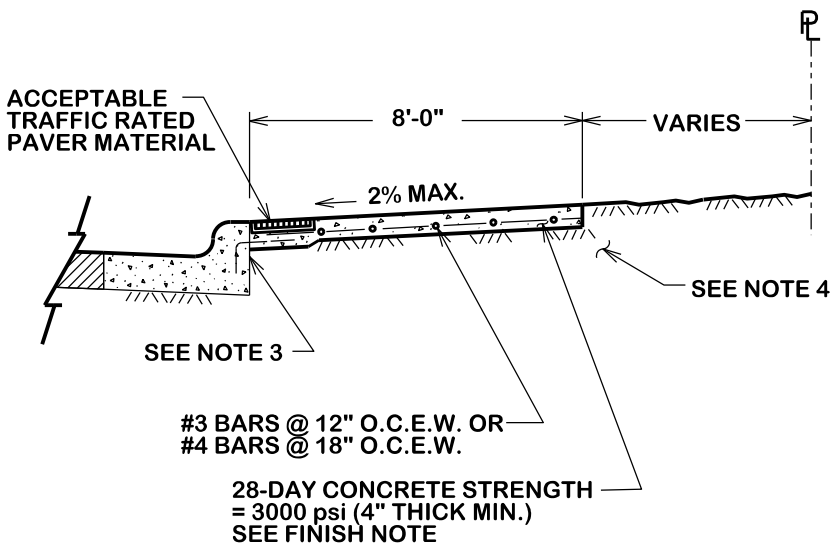

ALONG MINOR COLLECTORS AND LARGER

NOTES:

1. SIDEWALK PLACEMENT SHALL BE IN ACCORDANCE WITH B/CS UNIFIED DESIGN GUIDELINES.
2. FINISH: LIGHT BROOM FINISH. JOINTS TO BE TOOLED 1" DEEP AT AN INTERVAL EQUAL TO THE SIDEWALK WIDTH. EXPANSION JOINTS @ 40' O.C., CONTRACTION JOINTS @ 4' O.C.
3. DOWEL IN AND TIE TO ANY CONCRETE STRUCTURE ADJACENT TO SIDEWALK (DRIVEWAY, INLET BOX, CURB, JUNCTION BOX, ETC.) WITH #3 x 12" BARS @ 12" O.C. OR #4 x 12" BARS @ 18" O.C. DOWEL IN CURB SHALL MAINTAIN MIN. 2" COVER FROM THE TOP OF CURB AND SHALL EXTEND INTO CURB A MIN. OF 2.5" AND A MAX. OF 3.5". INCLUDE TYPE "G" EXPANSION JOINT AT CONNECTION WITH BACK OF CURB.
4. COMPACTION: COMPACTED SUBGRADE MATERIAL COMPACTED TO A DENSITY AT LEAST 98% OF MAXIMUM DRY DENSITY AS DETERMINED BY PROCTOR COMPACTION TEST ASTM D698 (STANDARD) AND SHALL BE 0-4% WET OF THE OPTIMUM MOISTURE CONTENT
5. A MINIMUM CLEAR PEDESTRIAN WIDTH AS DEFINED BY TAS AND ADA SHALL BE PROVIDED FOR ENTIRE LENGTH OF SIDEWALK.
6. ALL SIDEWALKS, INCLUDING PRIVATELY-OWNED, PERPENDICULAR TO STREET SHALL HAVE TYPE "G" EXPANSION JOINT AT CONNECTIONS WITH BACK OF CURB, BOTH SIDES OF LONGITUDINAL SIDEWALK, AND AT PROPERTY LINE.

 CITY OF BRYAN <small>The Good Life, Texas Style.</small>	8' CONCRETE SIDEWALK		 CITY OF COLLEGE STATION
	DATE OCT. 2016	B/CS UNIFIED STANDARD DETAIL	